



Depósito Carat XXL 16.000L



Código 380001



Depósito Carat con cubierta paso peatones

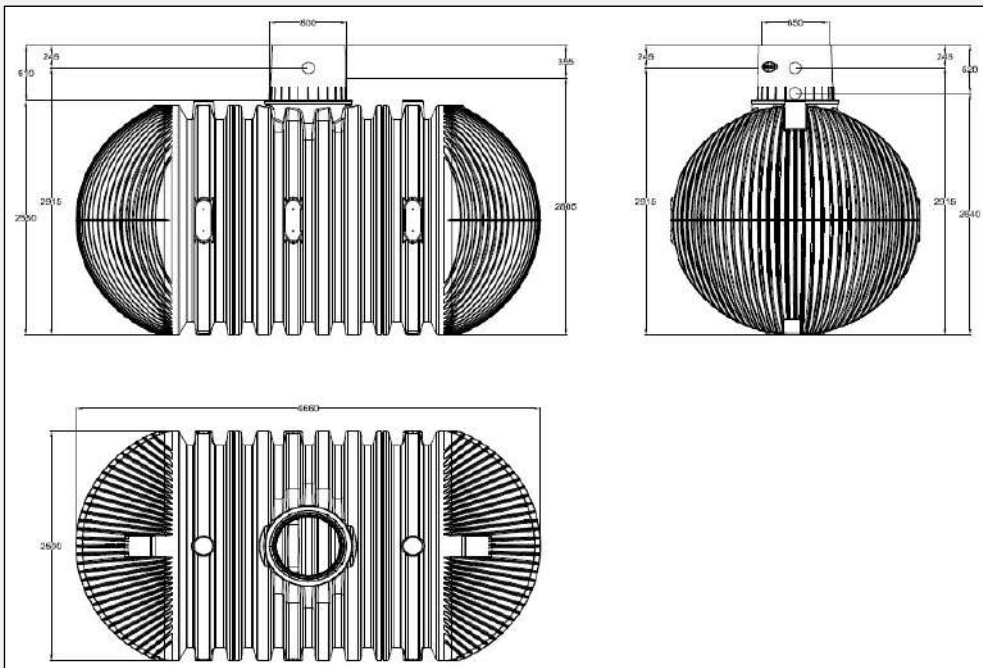

Depósito GRAF Carat XXL 16.000L	
Volumen total	16.000L
Material	PE
Diámetro bocas	DN 600
Número bocas	1
Medidas (LxAxh)	4660mm x 2500mm x 3300-3500mm

INCLUYE	Depósito Carat XXL 16.000L
	1 Cúpula Maxi
	1 Cubierta telescópica transitable por peatones
	Kit de juntas para el montaje del depósito

OPCIONES

CUBIERTA FUNDICIÓN PARA PASO VEHÍCULOS	EXTENSIÓN DE CÚPULA
--	---------------------

MANTENIMIENTO CADA 5 AÑOS
VACIADO COMPLETO DEL DEPÓSITO
LIMPIEZA DE LAS SUPERFICIES Y PIEZAS DE MONTAJE CON AGUA
ELIMINACIÓN DE LA SEDIMENTACIÓN ACUMULADA EN EL DEPÓSITO
COMPROBACIÓN DEL ASENTAMIENTO DEL DEPÓSITO

CERTIFICADOS
Certificado CE
Certificado 89/106/EWG
Certificado EN 12566-3 anexo C6
Certificado EN 12566-3 anexo D2



Información técnica - 01/2021
 Todos los datos mostrados tienen una tolerancia de aprox. +/- 3,0 %
 Sujeto a modificaciones técnicas

info@grafiberica.com
 www.grafiberica.com
 Tel. : +34 972913767
 Fax. : +34 972913766



Filtro Universal XL Interno

Código 340107

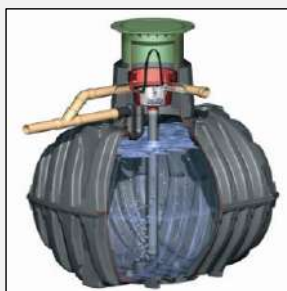
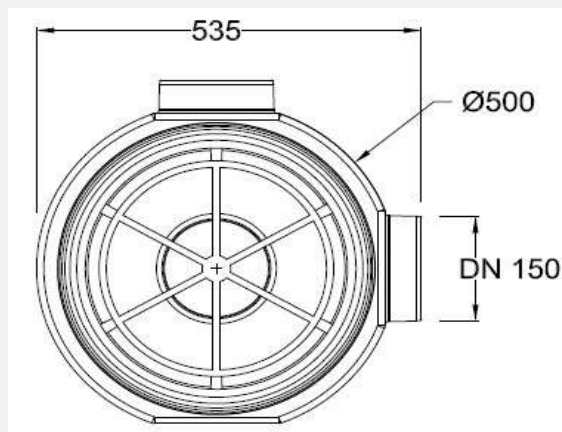
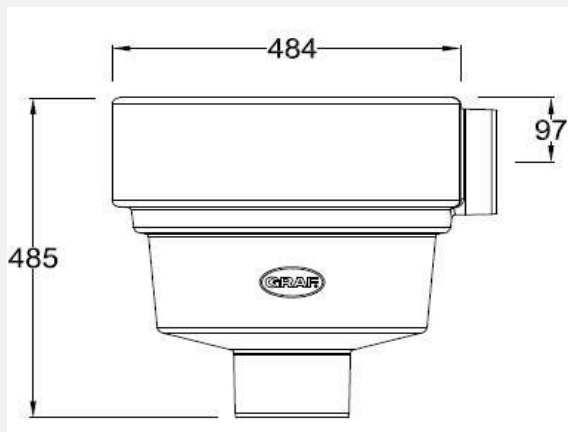

Filtro universal interno en depósito GRAF Carat

Filtro Universal interno

Reja de filtración

Filtro Universal interno	
Superficie max. recogida	500m ²
Material	PE, metal
Diámetro bocas	DN 150
Número entradas / salidas	2 / 2 (1 hacia depósito, 1 rebosadero)
Medidas (LxAxh)	535mm x 535mm x 485mm

INCLUYE	Estructura Filtro Universal interno
	Rejilla de filtración 0,35mm
	Asa de extracción filtro

OPCIONES

CESTA DE RECAMBIO

FIJACIÓN RÁPIDA SPANNFIX

MANTENIMIENTO

COMPROBACIÓN DE LAS CONEXIONES DEL FILTRO

LIMPIEZA DE LA REJILLA DEL FILTRO

CERTIFICADOS

Certificado TÜV

Información técnica - 01/2021
Todos los datos mostrados tienen una tolerancia de aprox. +/- 3,0 %
Sujeto a modificaciones técnicas

info@grafiberica.com
www.grafiberica.com
Tel. : +34 972913767
Fax. : +34 972913766



Bomba Integra Inox



Código 354018



Bomba Integra Inox

Potencia	0,6 kW
Presión de trabajo	4,4 bar
Altura máx. suministro	40m
Caudal máximo	3.000 l/h
Altura máx. succión	8m
Longitud máx. succión	12m
Profundidad máxima	10m

INCLUYE

Bomba Integra Inox
10m de cable de alimentación
Arranque / Paro automático
Press Control incorporado
Protección para no trabajar en seco
Cuerpo inoxidable

MANTENIMIENTO

COMPROBACIÓN DE LAS CONEXIONES DEL EQUIPO
LIMPIEZA DEL FILTRO DE CAPTACIÓN DEL DEPÓSITO

CERTIFICADOS

DIN 1988

Información técnica - 01/2021
Todos los datos mostrados tienen una tolerancia de aprox. +/- 3,0 %
Sujeto a modificaciones técnicas

info@grafiberica.com
www.grafiberica.com
Tel. : +34 972913767
Fax. : +34 972913766

APPLICATIONS

- Domestic Boosting
- Fountains and water-plays
- Medium sprinkling and sliding irrigations
- Depletion and pouring off of tanks
- Feeding of collection tanks

Sucked liquid:

Clean water, without abrasive and suspended parts

INSTALLATION

Steel pumps electropumps are suitable for:

- surface installation
- submerged installation

TECHNICAL FEATURES

- Pump body : stainless steel Aisi 304
- Motor body: stainless steel Aisi 304
- Back bracket: stainless steel Aisi 304
- Shaft: stainless steel Aisi 416
- Diffuser Impeller and Venturi Jet: Techno-polymer
- **Mechanical Seal: silicon-silicon**
- Class F cooled motor and Service S1 with thermic protector
- Electric power cable H07 RN-F mt. 10 with plug
- **Protection class of the pump IP 68**
- Temperature of the pumped liquid from +2°C to +37°C (18 to 70 Fahrenheit)

AUTOMATIC VERSION

- Electronic board with Microprocessor
- Flow sensor with cobalt Samario magnets
- Pressure gauge
- Built-in check-valve
- Techno-polymer safety-box for the board opening-area

X-JE

Self-priming centrifugal pumps

X-AJE

Self-priming pumps with electronic system



Handle ERGOGRIP
(Optional)

WORKING FEATURES

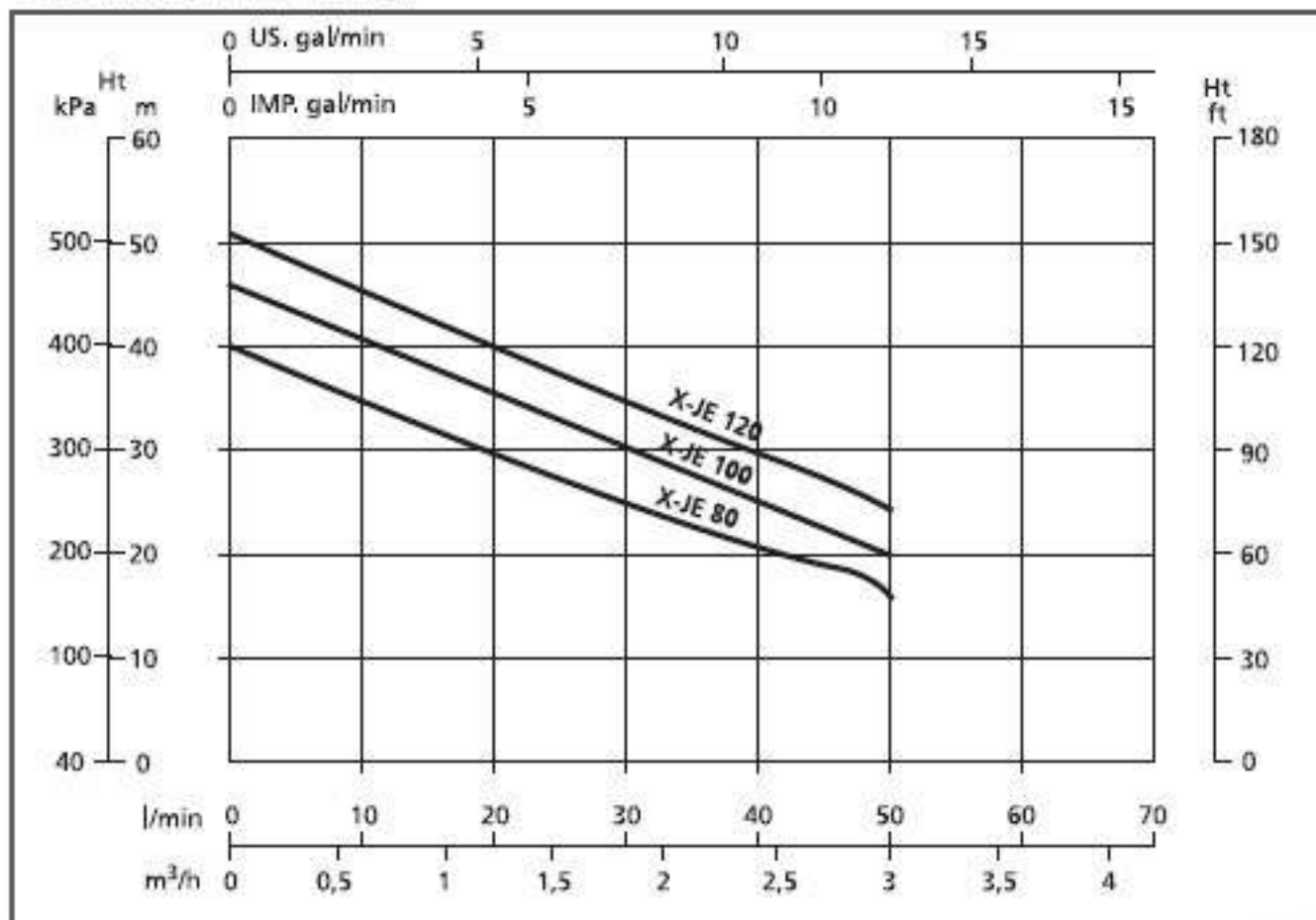

Motor body with suction port



Cable fixing bridge



Techno-polymer impeller

HYDRAULIC PERFORMANCE TABLE

CODE	Volt. Hz 50	Nominal Power P_2		Capacitor		Input Current Amp. 1 - 230	CAPACITY							
		kW	HP	μ F	Vc		Q lt/min	0	10	20	Total head			
											30	40	50	60
X-JE80	230	0,60	0,8	16	450	4,5	H m	40	33	30	24	20	15	
X-JE100	230	0,75	1	18	450	5,3		47	40	35	30	25	20	5
X-JE120	230	0,90	1,2	20	450	5,9		51	45	40	34	30	24	8

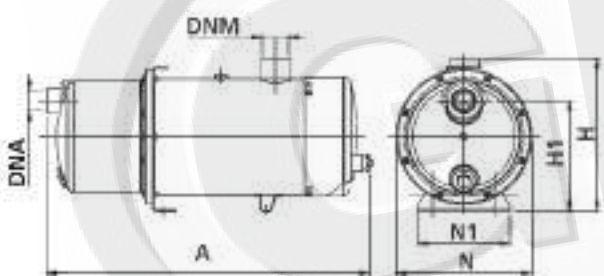

SIZE AND WEIGHT

CODE	Dimensions (mm)							Weight kg
	A	N	H	H1	N1	DNM	DNA	
X-JE80	477	200	226	163	136	1" 1/4	1"	14,50
X-JE100	477	200	226	163	136	1" 1/4	1"	15
X-JE120	477	200	226	163	136	1" 1/4	1"	16